

BOARD OF TRUSTEES

East Carolina University

February 25, 2011

The Board of Trustees met in regular session Mendenhall Student Center. David Brody, chair of the Board, called the meeting to order and read the conflict of interest statement required by the State Government Ethics Act. No conflicts were identified.

Mr. Brody asked Assistant Secretary John Durham to call the roll.

Members Present

Bill Bodenhamer

Robert Brinkley

David Brody

Joel Butler

Ken Chalk

Bob Greczyn

Steve Jones

Bob Lucas

Carol Mabe

David Redwine (via phone)

Danny Scott

Tremayne Smith

Mark Tipton

APPROVAL OF MINUTES

Mr. Brody asked for a motion approving the minutes from the Board meeting on November 19, 2010 and the conference call meetings on December 20, 2010 and January 27, 2011. Mr. Butler moved approval of the minutes. Mrs. Mabe seconded the motion. The motion passed with no negative votes.

CHANCELLOR'S REPORT

A text version of Chancellor Ballard's remarks to the Board is included as Attachment A.

REPORT FROM THE CHAIR OF THE FACULTY

A text version of Dr. Walker's remarks to the Board is included as Attachment B. Mr. Greczyn said that the progress on the Faculty Manual has been admirable and commended the Faculty Senate on its hard work. He said that it is more important to "get it right than to get it done quickly." Dr. Walker and everyone involved should be complimented, he said. Mr. Brody concurred. He said that what you think you know and what you know are two different things and that it might be helpful for the Board in making decisions to have a better idea about what the typical faculty week is like.

REPORT FROM THE SGA

SGA President Tremayne Smith gave remarks to the board. A text version of his comments is included as Attachment C.

REPORT OF THE BOARD OF VISITORS

Chair of the Board of Visitors, Mr. Reid Overcash, gave the report to the Board. He gave an update on the last Board of Visitors meeting on February 4, 2011. At that meeting, Chancellor Ballard gave an overview of what's going on at ECU as well as an update on the budget. Mr. Overcash gave an overview on the BOV Committees. The Fundraising and Developing Committee is co-chaired by Olivia Collier and Delores Parker. Currently, the Board of Visitors funds three Access Scholarships and it is getting close to funding four. The

Engagement Committee is chaired by Steve Brown who is also the Vice Chair of the Board of Visitors. The Engagement Committee is the “keeper of the watch list” of prospective new members. The Legislative Committee, chaired by Terry Yeargan is the largest committee, but it is highly organized and very engaged. They stand ready to help when called upon. The next meeting is May 20 in Raleigh, and as always, the BOT are invited to attend.

COMMITTEE REPORTS

AUDIT COMMITTEE

Mr. Joel Butler gave the Audit report. A summary of his report is included as Attachment D. There were no action items.

FACILITIES & RESOURCES COMMITTEE

Mr. Bodenhamer gave the Facilities and Resources Committee Report in Mr. Redwine’s absence. A summary of his report is included as Attachment E. There were several items that required the Board’s attention.

Mr. Bodenhamer asked that the Board approve of the naming of the Brinson-Christian Ecology Laboratory in the Howell Science Building as presented in Board materials. The motion passed with no negative votes. Supporting documents are listed as Attachment F.

Mr. Bodenhamer asked that the Board approve the naming of the Athletics Auxiliary Gym in accordance with the terms and conditions provided in the Board materials. The motion passed with no negative votes. Supporting documents are listed as Attachment G.

Mr. Bodenhamer asked that the Board approve the Stratford Arms acquisition in accordance with the terms and conditions provided in the Board materials. The motion passed with no negative votes. Supporting documents are listed as Attachment H.

Mr. Bodenhamer asked that the Board approved the Harvey House acquisition in accordance with the terms and conditions provided in the Board materials. The motion passed with no negative votes. Supporting documents are listed as Attachment I.

Mr. Bodenhamer moved approval of the Water Line Easement to Greenville Utilities Commission in accordance with the terms and conditions provided in the Board materials. The motion passed with no negative votes. Supporting documents are listed as Attachment J.

Mr. Bodenhamer moved approval of the Underground Electrical Easement to Greenville Utilities Commission in accordance with the terms and conditions provided in the Board materials. The motion passed with no negative votes. Supporting documents are listed as Attachment K.

Mr. Bodenhamer moved that the Board approve the city of Greenville, ECU, TRUNA Vision Statement in accordance with the terms and conditions provided in the Board materials. The motion passed with no negative votes. Supporting documents are listed as Attachment L.

HEALTH SCIENCES COMMITTEE

Mr. Steve Jones gave the Health Sciences report. A summary of his report is listed as Attachment M. There were no action items.

UNIVERSITY AFFAIRS COMMITTEE

Mr. Bob Lucas gave the University Affairs report. A summary of his report is listed as Attachment N. There were no action items.

EXECUTIVE COMMITTEE

Mr. Lucas gave the report from the Executive Committee. Mr. Lucas moved approval of the conferral of tenure from the Academic Affairs Division and the Health Sciences Division as presented in Board materials. The motion passed with no negative votes. A list of tenure approvals is included as Attachment O.

Mr. Lucas moved approval of the petition for political activity for Calvin Mercer as presented in Board materials. The motion passed with no negative votes. The petition and supporting documents is included as Attachment P.

REPORT FROM THE CHAIR

Mr. Brody commented briefly on an article in Trusteeship magazine, "Making Metric Matter." Dr. Ballard, Mr. Brinkley, Mr. Brody, Dr. Sheerer, Dr. Niswander and Dr. Weismiller had a discussion about developing dashboards for the Board. Mr. Brody suggested that Dr. Weismiller make a laundry list or dashboards for each committee and the Board as a whole to give all Board members a "snapshot" of what's going on in each committee.

UNFINISHED BUSINESS

There was no unfinished business.

NEW BUSINESS

Mr. Brody appointed a nominating committee, chaired, by Mr. Greczyn. The committee will also consist of Mr. Bodenhamer and Mr. Butler. Mr. Brody asked for a report at the April 15 meeting. Mr. Greczyn asked for as much feedback from each board member as soon as possible.

ADJOURNMENT

Mr. Brody reminded Board members of the ribbon-cutting at the newly remodeled Croatan. He adjourned the meeting at 10:30 a.m.

Respectfully Submitted,

John Durham
Assistant Secretary to the Board

Chancellor's Remarks

February 25, 2011

Thank you Chairman Brody.

I want to address four topics today:

- A brief summary of the budget process;
- The recent visit by Dr. Ross to ECU
- A legislative update; and
- The James R. Talton Leadership Award

The Budget

Most of the Board heard the budget presentation yesterday and I won't repeat that. Suffice it to say that the higher education budget is pretty frightening. We face threats from a number of sources and we won't know the results for several more months. We are already an underfunded university, and that certainly does not help.

That said, we have sound plans and we are moving forward. We will do our part and we will maintain our mission and our priorities... we just may not be able to do all that we have historically done.

We continue to communicate directly with every constituency of the university, from the faculty senate budget committee to every academic college. We have now completed 3 college-level budget forums, with 7 to go. The academic council is reviewing every budget plan and we have strong campus guidelines for how we spend scarce resources. We have a strong resolution of support from the Senate Budget committee and we appreciate the work of Scot MacGilvray and that committee.

The key to our future is to continue to make a difference for North Carolina and I hope each of you helps to tell our story. It is a great story.... Ranging from PJ Schenarts who just returned from Afghanistan...his 4th tour there... to the work of the Health Disparities Center under Hope Landrine to the assistance we are providing to communities from West Greenville to New Bern to Tillery.

Ross Visit

Tom Ross and Jeff Davies, his chief of staff, visited our campus about one week ago and Tom said they had an excellent visit. I think they caught the Pirate spirit and by the end of the day both were pronouncing A-R-R-R-G-G-GH-H at a reasonable level. I don't think we have to convince them what we mean for North Carolina... they get it!

During their visit, they frequently asked what our challenges are and I believe they are ready to help us with those challenges as we move forward. They know that the bio-science building probably heads that list...before Howell Science literally falls down. They also know that better state support for health sciences and indigent care is vital.

ECU did a lot of preparation for this visit and I want to thank John Durham and Philip Rogers for ensuring everything was ready and on-time. We ran better than a German train. In addition, all seven sessions were handled with quality. I thought our faculty and student groups were especially on point and I know they made an impression on our visitors.

Legislative Update

Philip Rogers and I have been working hard on legislative matters, with significant help from our Board of Visitors. Philip spends so much time in Raleigh I think they will have to get him an office. It is only a matter of time before he is Governor and I'll have to call him "Your Honor" or "Your Majesty..."

The challenge this year is to build new relationships with 42 new legislators. Plus, many of the decision making processes are different... so it requires constant work.

I think our work is paying off in terms of our key item this year, operational dollars for the Dental School. I hope you have noticed that the Governor included full funding in her budget and we are hoping that the legislature approves this aspect of the Governor's budget. We are fortunate to have several Republican co-sponsors for this specific bill and have received positive feedback from the leadership regarding the importance of completing the investment already made by the state. This funding is required for our continued accreditation, which gets reviewed every 2 years during the early stages of operation of the School.

It was very encouraging that Gov. Perdue made a brief visit to the dental school construction site last week on the day that she released her budget. She was very supportive of completing that project.

In addition, other important items this session include:

- Our request to retain rental receipts from the new Cancer Joint Venture, which would amount to \$500,000 dollars each year. While these funds are very important to our funding of cancer services, we face an uphill battle to keep these receipts... primarily because of the state budget gap.
- From a system-wide perspective, the UNC Board of Governors will continue to promote three strategic priorities during the biennium: (1) Minimizing the cuts to the university and maximizing our flexibility; (2) Enrollment Growth Funding; and (3) Need-based financial aid
- On Wednesday of this week, Republicans announced spending targets for each major committee within state government. While no final decisions have been made, Republics intend to spend a total of \$10.5 billion on the three educational entities of the state (K-12, Community Colleges, and Universities) for the biennium, which would account for approximately a 12% cut if divided equally among all three educational entities. Governor Perdue's budget, which was released last week, called for \$11.2 billion in spending on education or a 9.5% cut to the university system

James R. Talton Award for Leadership

Many of you knew Jim Talton and he was certainly a special person for me during my first two years. He was a prime reason I came to ECU.

I am very proud to say that we have created the James R. Talton Leadership Award and I want to thank Austin Bunch for the idea and the work to get it done. The Award will be given each year to recognize a member of our community... student, faculty or staff ... who, like Jim, exemplifies servant leadership, strong character, and ethical behavior, and “uncommon commitment to service.” I look forward to recognizing the first recipient of the Talton Leadership Award at University Awards Day on April 26. I look forward to recognizing the first recipient of the Talton Leadership Award at University Awards Day on April 26.

That concludes my remarks today and I'm happy to answer any questions.

Faculty Senate Chair Remarks

February 25, 2011

I. Greetings - from the faculty and the faculty senate

My remarks today will briefly summarize the many activities/issues facing the faculty at East Carolina University.

II. Budget – As you are all aware, the budget has everyone buzzing; but the manner in which our administration is handling and informing the faculty is commendable. As you heard yesterday, the administrative team consisting of the Chancellor, Vice Chancellor for Finance (Dr. Niswander), the Provost, Vice Chancellor for Health Sciences, and respective Deans are meeting for budget forums with each individual college. I have been asked to attend each of the forums and am keeping notes on the questions/concerns from the faculty in each of the forums. In the three forums that have been held, concerns and questions have been unit specific, but common in the theme including questions about 1) fixed-term faculty seniority and loss of positions (in the event that fixed-term faculty are not rehired), 2) issues surrounding funding model and affects on class size, 3) furloughs, 4) cuts or duplication of programs and relationship to preservation or expansion of existing degree programs.

I applaud the administration in taking valuable time to meet and provide the faculty with budget information, as it unfolds, and how the university will plan for budget cuts.

I also want to publically thank the Chancellor for involving two of our standing university academic committees in this process – the University Budget Committee and the Educational Policies and Planning Committee (commonly known as EPPC) in planning and communicating to faculty about this current budget situation. EPPC has been charged by the Chancellor to assist in defining the criteria for potential program prioritization (including, but not limited to – consolidation criteria, and criteria for elimination and curtailment of programs).

The Chancellor, Provost, in addition to the other members of the Executive Council have consented to this faculty infusion and shared governance approach and have been transparent in their communication with the faculty from the beginning regarding this budget dilemma.

So, I see three primary areas for faculty involvement in this budget situation –

- a) Educating the faculty on the current budget and management of such and how the budget will be affected depending on the NC State budget outcomes and affects to UNC, ECU, and to our academic programs. Also this approach will allow the faculty to understand decisions of the Dean's, Vice Chancellors and Chancellor.
- b) Allowing faculty to have a role in determining criteria for program prioritization and budget management through various committees. This does not exist in this manner in all UNC universities.
- c) Need to tell our story – General Public needs to better informed about the many roles of faculty and of the excellence of the faculty we have at East Carolina University. I would like to execute a campaign to obtain as many stories as possible on faculty that showcase the scholarship of the discipline, the intricacies of the curriculum (including undergraduate, graduate, and doctoral levels), relationship of

these areas to research and creative activities and to service for the community and beyond. We need profiles that demonstrate the excellence and commitment of individual faculty across our many degree programs.

III. Faculty Manual - We continue to plug along with this endeavor. As I stated in my remarks in November, the Faculty Senate and its committees are truly scrutinizing each section and are thoughtfully considering all contemporary issues during this review. 82 of 131 have been and we still have two months left in the semester. As an example, as we were discussing a section on Weapons policy, one of the senators raised a question about when a faculty member may be on an underwater archeology mission on a shipwreck and uncovers a cannon or cannonball, would this be considered possession of a weapon. Once we found the reference to the statue, we determined that this would not be in violation of this policy! A little humor is always helpful in a faculty senate meeting.

The majority of the faculty manual will be completed by April, however, there are a few sections that may be under discussion and may delay completion under the fall. Issues surrounding personnel policies (i.e. annual report) faculty constitution, and appellate committee procedures may be delayed pending further discussion on professional ethics and updated committee membership and charges. These pending sections, however, have been under discussion but further research and vetting is needed in these areas. However, anything is possible and there could be a possibility for completion pending these discussions.

I have an updated matrix for Mr. Brody, Mr. Grezchan, and Chancellor Ballard. Mr. Brody, in the event that we have not completed the manual when you rotate off the Board, we will invite you back for our celebration when it is completed!

IV. Other activities - Faculty are busy with many endeavors, in addition to their primary roles in teaching, engaging in research and mentoring students in research, and other scholarship activities, and clinical services – with campus priorities including SACS reaffirmation, developing and establishing standards and process of review for online teaching, in determining Key Performance Indicators that define and measure outcomes for the university strategic plan.

V. Gratitude - I end with an expression of gratitude for this great university and for all the players, administrative, faculty, staff, and students, who make ECU the best university. We are fortunate to have senior administration that truly value shared governance and the roles of the faculty in our many initiatives. We are also fortunate to have such an excellent faculty who are dedicating additional time and work into the revision of the Faculty Manual. We will have the best manual in the system when we are finished. Also, thanks to the BOT for your support as well, especially in recognizing the work that has been devoted to the revision and reorganization of the Faculty Manual.

Student Body President Remarks
 Tremayne B. Smith
 East Carolina University

Feb. 25, 2011

Since our last meeting, the Student Government has been working very very hard and getting a lot of things done.

New Business

Judicial

- Shipmates
 - Shipmates- touring the Athletic Committee
 - Elections Committee- being decided

Legislative

- Senate seeking to pass a resolution expanding the Univ. sexual harassment policy on campus to be more comprehensive and cover other forms of discrimination (Gender, Sexual Orientation)
- Will be hosting the Crime and Safety Forum next week Monday Feb 28th @ 6 PM
 - the Greenville Police Department hosted a community forum at City Hall but while students were on Winter recess. GVPD Chief Anderson contacted me to say he wanted to afford students the opportunity to weigh in on the ongoing discussion of safety, as we are a large constituent of the City.
 - The forum will discuss the following:
 - What are the major challenges limiting police-community relations in Greenville?
 - What are the reasons that those challenges exist?
 - What are the goals for police-community relations in Greenville?
 - What are some ideas to improve relations? (brainstorm)
- Recently completed our First Town Hall for Organizations and heard their concerns. Provost along with many of the Deans of the Colleges attended the College Town Hall yesterday.
- Elections Committee to be confirmed after Spring Break.

Executive

1. Cabinet
 - a. Success for Life series-monthly event to discuss topics important to students and are aimed at helping students be successful.
2. Secretary
 - a. Partnered with Dowdy Student Stores to have give-aways including apparel and pirate items from Dowdy Student Store and gift cards that can be used there as incentives for responding to us and providing input.
 - b. Join the ECU SGA Facebook group at [facebook.com/ecu.sga](https://www.facebook.com/ecu.sga)
 - c. Join the ECU SGA on Twitter @ECU_SGA

3. Treasurer
 - a. New Funding process that makes receiving funding for registered campus organizations easier.
 - i. SGA has allocated more money than ever to more student organizations than ever
 - ii. If we continue with the allocation rate we are going at, we are looking to have allocated 95% of the monies designated for Student Organization allocation.
4. President

Credit Card Fraud Updates/ Responsibilities of SGA

- Higher One will be cancelling and reissuing all cards on Wednesday.
- We have received numerous phone calls regarding the issue. Now, 100 active cases.
- Hacking was done outside of U.S. Feds possibly to get involved
- Send us info about further cases. We can communicate the problems to higher administration.
- Make sure to contact police, contact UBE, & HigherOne, to make sure the situation that you are in is known to the right people, not just the University.
- You will get your money back, it will take a while for that process to come through with it.

Understanding Budget Cuts

- No program has been cut yet. If that time comes, program will not be cut outright, but most likely phased out.
- Explain different money pots.
 - Master Planning & Budget Cuts majority do not clash with each other.
 - Other projects on campus are not a direct relation to the budget cuts.
- Provide examples of how SGA can assist in the process.

Upcoming Events

February 25-26, 2011

ECU Executives to ASG Elizabeth City State Univ.

March 15, 2011

7:00 pm SGA President to Garrett-Diversity presentation

Garrett Residence Hall

March 21-25, 2011

*SGA Diversity Week

March 25-26, 2011

ECU Executives to ASG

Winston Salem St. Univ.

March 23, 2011

*Presidential Town Hall

Joyner Library

March 30, 2011

*7:00 pm Presidential Town Hall

ECU School of Nursing

March 28, 2011

*7:00 pm SGA Success for Life-Interviews and internship

To conclude my report...The SGA will continue to operate to live out the motto of ECU which is Sevre- to serve. But as any servant will tell you, it can be easy to get burned out in your duties, so one thing I have committed my team to for the remainder of the semester is the notion of teamwork and relying on each other taken from the Biblical story of the Tower of Babel, where God say that they were building a tower and he remarked, “ if as one people speaking the same language they have begun to do this, then nothing they plan to do will be impossible for them.” So, we will all speak the same language, be on the same page and we will continue to serve and to fulfill the motto of this years SGA Administration and that is **LET DO WORK**...and so we shall.

East Carolina University
Report of Audit Committee Meeting
02/24/11

Action Items

- Approval of November 18, 2010 minutes
- Approval of revisions to Internal Audit Charter

Special Guests

- State Auditor – the Honorable Beth Woods attended the Audit Committee meeting along with two of her staff members. (Carol Smith and Ray Whitby).
- Mr. Whitby discussed the 06/30/10 financial audit; one audit finding reported; very complimentary of the cooperation and working relationship the State Auditor's Office has with ECU.

Internal Audit Report

- Internal Audit has completed follow-up review of corrective actions as it relates to the 06/30/10 State Audit report; satisfactory progress has been made with regard to correcting the deficiency noted in the report.
- Dashboard/Metrics: Internal Audit has completed 35% of the audit plan and 43% of the audit plan is in process; Currently management has implemented 87% of corrective actions.
- Results of Alumni, Pirate Club, and Medical Foundation financial audits were discussed. Foundations received unqualified opinion; however, there were a few instances of significant deficiencies/material weaknesses that were indentified. Management stated they would correct these items timely.
- Internal Audit is currently undergoing a Quality Assessment Review and results will be reported in the next few months.

ERM Report

- Update on Enterprise Risk Management efforts – Information provided included:
 - Mission and ERM Approach at ECU
 - Tone at the Top has been established by BOT Audit Committee and the Chancellor
 - Phases of the ERM Road Map – 4 Phases for a total of 20 steps; currently in implementation phase, which is phase 3.
 - ERMC Committee participated in a risk survey session and results of that session resulted in the following “Consolidated Risk Survey Results” – Major risk areas included:
 - Compliance 38%
 - Reputational 21%
 - Financial 17%
 - Strategic 14%
 - Operational 10%
 - Top risks in each major area were also presented.
 - Senior Leadership identified the following as major risk areas:

- Lack of formalized business process review
- Student Aid Processing and Administration
- Admin Support Structure and Internal Controls for Increased Size and Scope of Operations
- SACS and Specialized Skill Accreditation and Related Actions
- An example of a risk framework was also presented that may be a viable framework for ECU was also presented.

**ECU Board of Trustees
Facilities and Resources Committee
February 25, 2011**

Highlights

The Facilities and Resources Committee met on February 24, 2011.

University Advancement University

Naming Proposals

Brinson – Christian Ecology Laboratory in Howell Science Building. \$20K was raised by students, faculty and staff in honor of two professors (Mark Brinson and Bob Christian) Professor Brinson passed away unexpectedly January 3. There is a service on campus in March and it would be meaningful to family and friends if naming of the lab could be part of this ceremony. Therefore the committee approved the proposal and would like to ask for full Board approval today rather than waiting 30 days.

Additional Basketball Practice Facility Naming Opportunities were presented and approved by the committee. The full Board will see these individually as donors make the necessary gifts. So no action is required by the Board at this time.

Second Century Campaign Update

Mr. Dowdy shared the year end campaign total of \$190,216.000. Among the larger year-end commitments were \$1 million from BB&T, a Distinguished Professorship in Science Education from Tom & Liz Taft. Mr. Dowdy also expressed appreciation for commitments from Trustees Bob Grezcyn and Ken Chalk, both of whom are endowing Access Scholarships.

Mr. Dowdy shared with the committee that the campaign will run through the end of the calendar year and then other mini-campaigns supporting other areas of interest like the Honors College will be initiated.

ECU Brand Enhancement Task Force

Mr. Dowdy discussed the newly formed ECU Brand Enhancement Task Force to the committee and explained that the goal is to evaluate the reputation of ECU, compare the market research from 10 years ago and obtain new market research. Also, the task force will assess the communications/marketing organization in place and evaluate or recommend how to organize more effectively.

Other Advancement Highlights

Our Alumni program once again has been recognized within the CASE III district as one of the top Alumni Relations Programs. This is the third time in five years that our Alumni program has received such recognition.

Administration and Finance

Athletics Auxiliary Gym

The Committee reviewed a presentation of the Athletics Auxiliary Gym by Mr. Andy Cruickshank and Mr. Mike Hammersly of Corley Redfoot Zack. Mr. Bagnell was available for questions. The Committee approved a motion to recommend that the full Board approve the Athletics Auxiliary Gym.

Stratford Arms Apartments

The Committee reviewed a request to purchase Stratford Arms Apartments located at 1900 South Charles Boulevard from the East Carolina University Real Estate Foundation. Mr. Buck was available for questions. The Committee approved a motion to recommend that the full Board approve the purchase of Stratford Arms Apartments.

Harvey House Acquisition

The Committee reviewed a request to purchase the Harvey House located at 1200 East Rock Springs Road from the East Carolina University Real Estate Foundation. Mr. Buck was available for questions. The Committee approved a motion to recommend that the full Board approve the purchase of the Harvey House.

Water Line Easement

The Committee reviewed a request to grant a water line easement to Greenville Utilities Commission to expand water service to the Croatan Dining Hall. Mr. Buck was available for questions. The Committee approved a motion to recommend that the full Board approve granting the water line easement to Greenville Utilities Commission.

Underground Electrical Easement

The Committee reviewed a request to grant an underground electrical easement to Greenville Utilities Commission at ECU's Falkland Woods/Otter Creek Natural Area on NC Highway 43 near Falkland, NC. Mr. Buck was available for questions. The Committee approved a motion to recommend that the full Board approve granting the underground electrical easement to Greenville Utilities Commission.

City of Greenville, ECU, TRUNA Vision Statement

The Committee reviewed the City of Greenville, ECU, TRUNA Vision Statement. Mr. Ken Chalk was present for questions. The Committee approved a motion to recommend that the full Board approve the vision statement.

Freedom Wall and Memorial Walk

The Committee reviewed freedom wall and memorial walk documents as an information item. Dr. Steve Duncan was present for questions.

Debt Management Guidelines

The Committee reviewed ECU Debt Management Guidelines as an information item.

Master Plan Update

Dr. Niswander and Mr. Bagnell presented an update of the ECU Master Plan.

Capital Projects Update

Dr. Niswander and Mr. Bagnell presented an update of the current major capital projects. The current information for the major capital projects is available on the ECU website at <http://www.ecu.edu/cs-admin/bot/majorcapitalprojects.cfm>.

PROPOSAL TO EAST CAROLINA UNIVERSITY BOARD OF TRUSTEES
COMMITTEE ON NAMING UNIVERSITY FACILITIES AND ACTIVITIES

Jeffrey McKinnon
Name of Originator
Biology, THCAS 328-5258 mckinnonj@ecu.edu

Department/Division Phone Email

Proposed Name(s) to Honor: **Distinguished Research Professors Mark Brinson, Bob Christian: "Brinson-Christian Ecology Laboratory"**

ECU Dep. Biology
Address: City State Zip

Telephone: Home Business

Relationship to the University: Distinguished Research Professors (Retiring)

Proposed Object for Naming: Ecology Teaching Laboratory, Howell Science S309

Purpose for recommendation: Service Gift
Explanation (Attach background materials as appropriate to justify the recommendation)
Please see attached explanation.

If related to a gift:
Purpose of Gift: Annual Capital Endowment
Date of Original Commitment: _____
Amount of the Total Commitment: \$20,000
Amount Paid: \$20,000
Current Pledge Balance: _____
Status of Payments: _____
Was the gift part of a campaign: Yes No Define: _____
Was the project pre-approved: Yes No
Directed to: ECU Foundation Educational Foundation
 Medical Foundation Other

- If the Gift was more than \$25,000:
1. Attach a copy of the signed Letter of Intent.
 2. Define in detail any special arrangements or expectations the donor may have resulting from this Gift.
 3. If the Gift is other than cash or cash equivalent, explain the method of valuation, and the plan for liquidation.

Alan R. White
Signature of Originator

13 Jan 2011
Date

[Signature]

Rationale for Naming

Bob Christian and Mark Brinson are arguably the two most accomplished faculty members to have served in the Department of Biology. Both are Distinguished Research Professors, recognized with career achievement awards from the ECU Division of Research and Graduate Studies. Dr. Christian is also a Harriot College Distinguished Professor while Brinson was recently a runner-up for UNC System's Oliver Max Gardner Award, for the faculty member "who...has made the greatest contribution to the welfare of the human race." Each has brought millions of dollars in grants to Eastern Carolina and trained dozens of graduate students as well as thousands of undergraduates. Moreover, both were hired at a time when research was a lesser focus at ECU. Their contributions were critical to making the Department of Biology a research leader on campus and an international standout in research on the ecology of wetlands.

Both Dr. Brinson and Dr. Christian are retiring this year. In honor of their retirement, we wish to name an Ecology laboratory after them--rather than, say, starting a scholarship that may not be large enough to make a real difference in students' lives. The laboratory has an area of approximately 730 square feet. At present there are be virtually no named rooms in Howell, perhaps owing to the building's decrepit condition. Nevertheless, many alums have fond memories of their time in Biology.

We envision the funds raised toward the room-naming going into the Biology scholarship fund. We intend to issue scholarships using the funds directly, rather than from interest from an endowment.

We will initially pursue fund-raising in conjunction with a symposium to be held Aug. 28, 2010, in honor of Brinson and Christian's retirements. Then, and until our fund-raising goal is met, we will invite contributions to the scholarship fund in honor of the Brinson-Christian retirements. Each such contribution will be documented.

7/19/08
HOWELL BUILDING

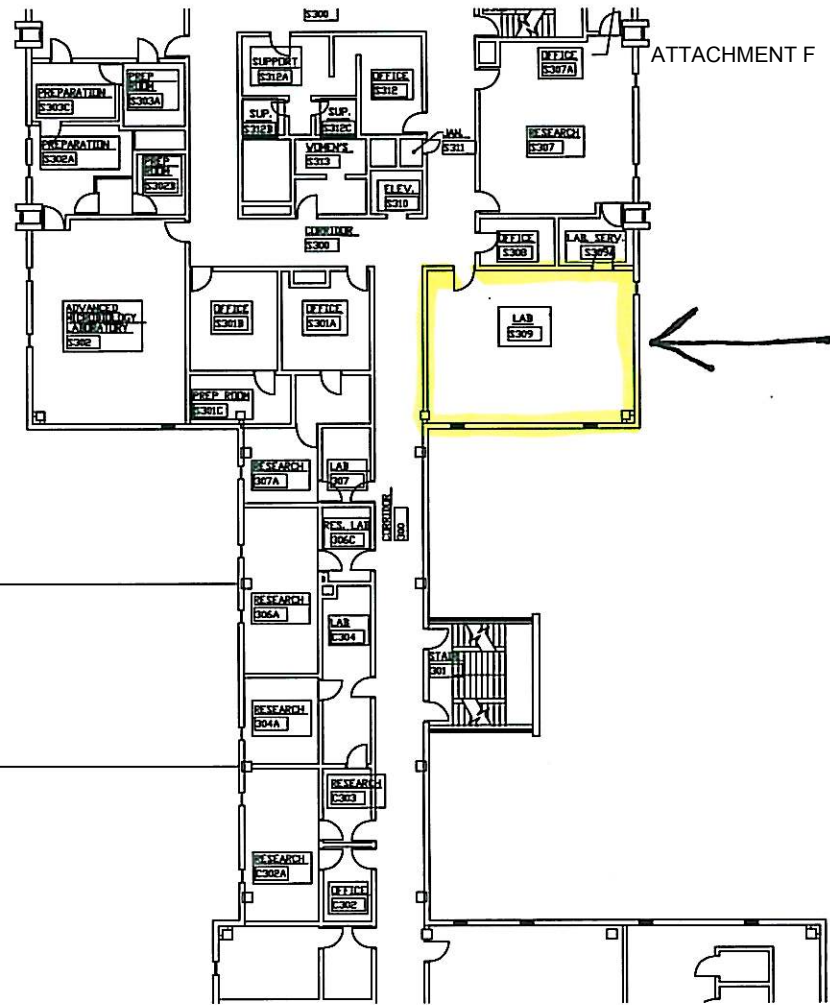
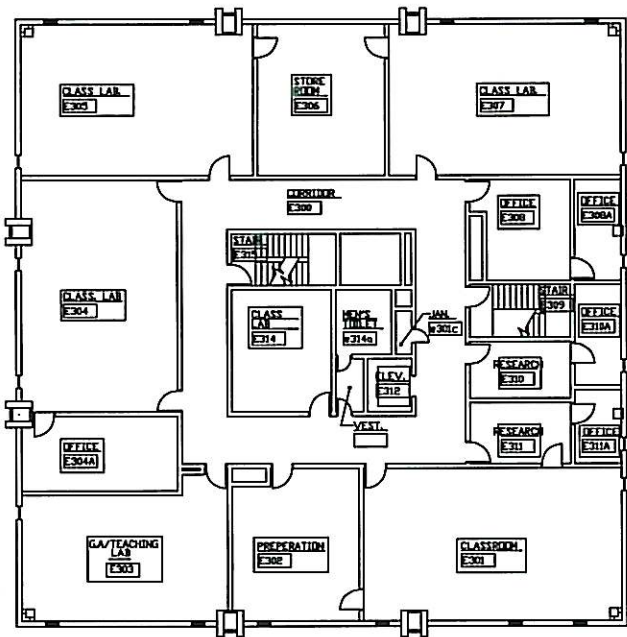

THIRD FLOOR PLAN PART
SCALE 1/8" = 1'-0"

**PROPOSED BASKETBALL PRACTICE FACILITY
NAMING OPPORTUNITIES**

PREVIOUSLY APPROVED BY BOT IN 2010:

BUILDING	\$2,000,000	(RESERVED)
MEN'S PRACTICE COURT	\$250,000	(RESERVED)
WOMEN'S PRACTICE COURT	\$250,000	
BASKETBALL OFFICE SUITE IN WSMB	\$250,000	
HEAD MEN'S COACH'S OFFICE IN WSMB	\$100,000	(RESERVED)
HEAD WOMEN'S COACH'S OFFICE IN WSMB	\$100,000	(RESERVED)
MEN'S STAFF CONFERENCE ROOM IN WSMB	\$100,000	

APPROVAL SOUGHT FROM BOT:

LOBBY/HALL OF FAME AREA	\$500,000
MEN'S OFFICE SUITE	\$250,000
WOMEN'S OFFICE SUITE	\$250,000
MEN'S TEAM LOUNGE & LOCKER ROOM	\$250,000
WOMEN'S TEAM LOUNGE & LOCKER ROOM	\$250,000
MEN'S TRAINING ROOM & OFFICE	\$100,000
WOMEN'S TRAINING ROOM & OFFICE	\$100,000
MEN'S OFFICE LOBBY	\$100,000
WOMEN'S OFFICE LOBBY	\$100,000
WOMEN'S STAFF CONFERENCE ROOM	\$100,000
MEN'S FILM/VIDEO ROOM	\$50,000
WOMEN'S FILM/VIDEO ROOM	\$50,000
MEN'S STAFF LOCKER ROOM	\$50,000
WOMEN'S STAFF LOCKER ROOM	\$50,000
MEN'S CORRIDOR/WARM-UP AREA	\$50,000
WOMEN'S CORRIDOR/WARM-UP AREA	\$50,000
MEN'S ASSISTANT COACHES' OFFICES (3)	\$25,000
WOMEN'S ASSISTANT COACHES' OFFICES (3)	\$25,000
MEN'S EQUIPMENT ROOM	\$25,000
WOMEN'S EQUIPMENT ROOM	\$25,000
TROPHY CASES IN LOBBY/HALL OF FAME AREA (3)	\$25,000
PEDESTAL DISPLAY CASES IN LOBBY/HALL OF FAME AREA (6)	\$15,000
REFEREES' LOCKER ROOM IN MINGES	\$25,000



Associate Vice Chancellor for
Administration and Finance - Business Services
East Carolina University
224 Ragsdale Building • Greenville, NC 27858-4353
252-328-6910 office • 252-328-1558 fax

MEMORANDUM

TO: Rick Niswander

FROM: Scott Buck *Scott*

DATE: January 24, 2011

SUBJECT: Request ECU Board of Trustees Approval to Purchase Stratford Arms Apartments at 1900 South Charles Boulevard

Request ECU Board of Trustees approval to purchase Stratford Arms Apartments, located at 1900 South Charles Boulevard, tax parcel #01448 from the East Carolina University Real Estate Foundation for a purchase price of \$3,125,000 plus closing and related carrying costs.

The parcel is strategic in nature and contiguous to the Belk Building and Blount Intramural Fields. The property consists of thirteen (13) individual apartment buildings, one (1) office building with two (2) efficiency apartments and a single maintenance building for a total of fifteen (15) structures with one hundred forty-six (146) apartments, supported by a swimming pool and three hundred twenty-five (325) parking spaces. Overall condition of the property is fair to good. Total buildings are 146,321 SF. A Phase I Environmental report was performed with no major issues identified.

Request approval to sever structures when deemed appropriate.

Purchase is contingent on Board of Governors, Joint Commission on Governmental Operations and Council of State approvals. Source of funds shall be auxiliary overhead receipt funds.

cc: Bill Clark
Mickey Dowdy
Joy Wayman
Tim Walton
Terrance Feravich



Associate Vice Chancellor for
Administration and Finance - Business Services
East Carolina University
224 Ragsdale Building • Greenville, NC 27858-4353
252-328-6910 office • 252-328-1558 fax

MEMORANDUM

TO: Rick Niswander
FROM: Scott Buck *Scott Buck*
DATE: January 24, 2011
SUBJECT: Request ECU Board of Trustees Approval to Purchase the Harvey House at 1200 East Rock Springs Road

Request ECU Board of Trustees approval to purchase property located at 1200 East Rock Springs Road, tax parcel #10546 from East Carolina University Real Estate Foundation for a purchase price of \$165,000 plus closing and related carrying costs.

The parcel is contiguous to university property and is deemed strategic in nature. The property contains a 2,144 single story lapboard house built in 1940 sited on .36 acres at the corner of 14th Street and East Rock Springs Road. Overall condition of the property is good.

Request approval to sever structure when deemed appropriate.

Purchase is contingent on UNC General Administration, Joint Commission on Governmental Operations and Council of State approvals. Source of funds shall be auxiliary overhead receipt funds.

cc: Bill Clark
Mickey Dowdy
Joy Wayman
Terrance Feravich



Associate Vice Chancellor for
Administration and Finance - Business Services
East Carolina University
224 Ragsdale Building • Greenville, NC 27858-4353
252-328-6910 office • 252-328-1558 fax

ATTACHMENT J

MEMORANDUM

TO: Rick Niswander

FROM: Scott Buck *Scott*

DATE: January 24, 2011

SUBJECT: Request ECU Board of Trustees Approval to Grant Greenville
Utilities Commission a Water Line Easement

Request ECU Board of Trustees approval to grant a water line easement to Greenville Utilities (GUC) to expand water service to the Croatan Dining Hall as shown on the attached survey map and legal description.

Granting of the easement is contingent on subsequent approvals from UNC General Administration, Joint Commission for Governmental Operations and the Council of State. Disposition of the easement shall be for one (1) dollar.

cc: Bill Bagnell
Joy Wayman
Terrance Feravich

Attachments

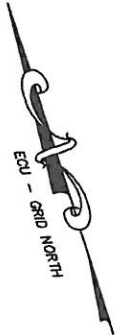

EAST CAROLINA UNIVERSITY
CROATAN DINING HALL



AS-BUILT LOCATIONS OF THE EXISTING WATER LINE WERE MADE BY B.R. KORNEGAY, INC. ON MAY 13, 2010.

THIS RECORD DRAWING IS PREPARED FROM DESIGN PLANS BY MOSER, MAYER, PHOENIX.

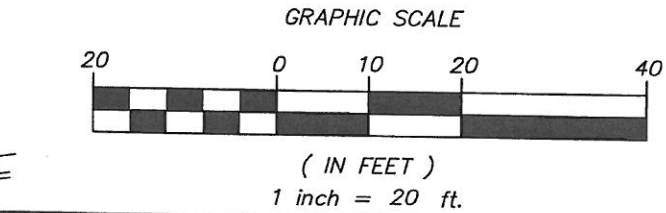
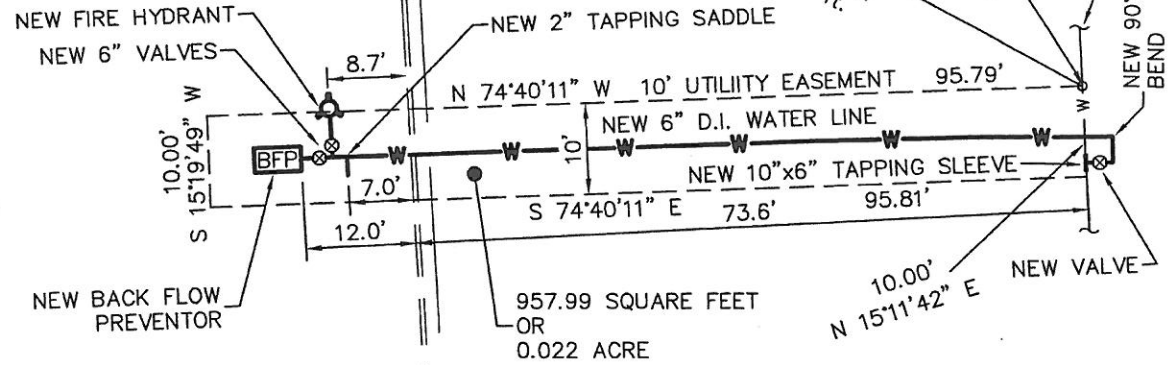

**EXISTING WATER LINE
RECORD DRAWING**

E.C.U. CROATAN DINING HALL
GREENVILLE, N.C.
PITT COUNTY

B. R. KORNEGAY, INC.
LAND SURVEYING · ENGINEERING · PLANNING
License Number: F-1054
P.O. Drawer 1435 · 300 East Walnut Street
Goldboro, N.C. 27533-1435
(919) 735-5886 Fax: (919) 580-9053

DRAWN BY: JLK
DESIGNED BY: —
DATE: 10-20-10
SCALE: 1" = 20'

SHEET: 1
OF: 1
WORK ORDER: 100404
CADD DWG: 100404

B. R. KORNEGAY, INC.

LAND SURVEYING • ENGINEERING • PLANNING
P.O. Drawer 1435 • 300 E. Walnut Street
Goldsboro, North Carolina 27533-1435
Firm No. F-1054

919-735-5886

Fax 919-580-9053



October 21, 2010

Description of Water Line Easement
within property located at East Carolina University-Croatan Dining Hall
City of Greenville, Pitt County, N.C.

BEGINNING at a point at an existing water line, said beginning point being located S 43° 28' 49" E 984.55 feet from a NGS monument entitled "Messick" having N.C. grid coordinates N: 679,941.12 E: 2,486,546.57, and said beginning point having N.C. Grid coordinates N: 679,227.989 E: 2,487,222.886; thence from the beginning N 74° 40' 11" W 95.79 feet to a point; thence S 15° 19' 49" W 10.00 feet to a point; thence S 74° 40' 11" E 95.81 feet to a point at an existing water line; thence along the existing water line N 15° 11' 42" E 10.00 feet to a point, the point of beginning containing 957.99 square feet or 0.022 acres more or less. Note: all bearings and distances refer to N.C. Grid, NAD 83 (2007)



Associate Vice Chancellor for
Administration and Finance - Business Services

East Carolina University
224 Ragsdale Building • Greenville, NC 27858-4353
252-328-6910 office • 252-328-1558 fax

ATTACHMENT K

MEMORANDUM

TO: Rick Niswander
FROM: Scott Buck *Scott*
DATE: January 24, 2011
SUBJECT: Request ECU Board of Trustees Approval to Grant Greenville
Utilities Commission an Underground Electrical Easement

Request ECU Board of Trustees approval to grant an underground electrical easement to Greenville Utilities Commission at ECU's Falkland Woods/Otter Creek Natural Area on NC Highway 43 North near Falkland, NC for one dollar (\$1.00).

This underground electrical easement will be within an existing easement that provides ingress/egress to adjacent property owner, so this easement will not leave any significant impact on ECU's property.

Attached please find a survey depicting the existing sixteen (16) foot easement and an aerial map of the site.

Granting the easement shall be contingent on subsequent approvals from UNC General Administration and Council of State.

cc: Bill Bagnell
Bill Koch
Joy Wayman
Terrance Feravich
Jeffrey McKinnon

Attachments (2)

NORTH CAROLINA
PITT COUNTYGRANT OF ELECTRICAL EASEMENT
DATE _____

KNOW ALL MEN BY THESE PRESENTS, that the undersigned "GRANTOR" (whether one or more), for and in consideration of the sum of ONE DOLLAR (\$1.00) and other good and valuable consideration to it in hand paid by GREENVILLE UTILITIES COMMISSION of the City of Greenville, Pitt County, North Carolina, hereinafter referred to as the "COMMISSION," the receipt of which is hereby acknowledged, does hereby grant the City of Greenville, a body politic and corporate in Pitt County, North Carolina, for use of the "COMMISSION," its licensees, successors and assigns, the right, privilege and easement to go in, through, under, and upon lands of the GRANTOR located in Falkland Township, Pitt County, North Carolina, and more fully described as follows:

Beginning at an iron in the northern right-of-way line of North Carolina Highway 43, said iron being located at the southwestern corner of the property now or formerly owned by Roger Peaden, a common corner with the lands now or formerly owned by Reid Parker Ellis; and thence from the BEGINNING POINT so established and down the east side of a farm path on the lands now or formerly owned by said Reid Parker Ellis in a northeasterly direction the following courses and distances: North 49 degrees 26 minutes 38 seconds East 209.555 feet, more or less, to an existing iron pipe, another corner with land now or formerly owned by the said Roger Peaden; thence with the Peaden line South 36 degrees 44 minutes 42 seconds East 104.75 feet, more or less, to an existing iron pipe, a corner with the lands now or formerly owned by the K.R. Wooten Heirs; and thence with the dividing line between the Wooten Heirs and said Reid Parker Ellis lands, North 49 degrees 52 minutes 47 seconds East 459.043 feet, more or less, to an existing iron pipe, a common corner of the Ellis land, and the lands of the Wooten Heirs, and the lands of Mrs. Leary W. Wilkinson. (Reference is hereby made to Book J51 at Page 767, and Map Book 31 at Page 1, Pitt County Public Registry.) Said easement herein conveyed is sixteen (16') feet wide and runs in all respects parallel with the line above described. Reference is hereby made to a map entitled "Access Easement for Charlie Wilkinson" made March 13, 1979 by McDavid Associates, Inc., Farmville, N.C., appearing of record in Deed Book X47 at Page 835, in the Office of the Register of Deeds of Pitt County, North Carolina. Reference is hereby further made to that certain plat entitled Survey for Roger Eugene Peaden and wife Ellen Baker Peaden, Deed Book R35, Page 167, Falkland Twp., Pitt County, NC, dated October 23, 1991, prepared by William F. Jefferson, RLS L-1405, McDavid Associates, Inc., Engineers-Planners-Land Surveyors, Farmville, NC and Goldsboro, NC, which appears of record in Map Book 40 at Page 113, Pitt County Public Registry.

(Reference is hereby made to Deed Book X47 Page 833, and Book 1047 Page 289, and Deed Book 146 Page 275, and Map Book 40 at Page 119, in the Office of the Register of Deeds of Pitt County, North Carolina) and to construct, install, operate and maintain an underground electric transmission line in a manner suitable to the Commission upon, across, under and through said premises within an easement and right of way strip of the width, location and approximate length hereinafter defined and to be utilized by the Commission a permanent easement and a temporary construction easement for the public use with the right to do all things necessary or convenient thereto, including the following:

- (a) the right of officers, agents, and workmen of the Commission and its contractors to go to and from said right of way strip at all times over the above described land by such route or routes as shall occasion the least practicable inconvenience to Grantor, including private roads and ways then existing thereon, on foot or by conveyance, with materials, machinery, supplies and equipment as may be desirable; provided that except in emergencies, existing roads and ways thereon shall be used to the extent that they afford ingress and egress to and from the right of way strip; and to construct, reconstruct, work upon, repair, alter, inspect and in general do any other thing necessary or convenient to maintain and operate said lines for the purpose aforesaid;
- (b) the right and privilege to enter upon the land included in the construction easement hereinabove described for the purpose of constructing said utility facilities, and the right

and privilege at all times to enter upon the land included in the area of the permanent easement hereinabove described for the maintenance and repair of said utility facilities;

- (c) the right to clear, and keep cleared, from said right of way strip all structures (other than ordinary fences, but when Commission desires, such fences may be opened and reclosed or temporarily removed and replaced, or Commission may provide suitable gates therein) and all vegetation which may interfere with the utility facilities herein described and to use (1) chemicals which are not injurious to human beings, domestic animals, fish or game, (2) machinery, and (3) other forms of equipment and devices in so doing;
- (d) the right to install, construct, repair, maintain and operate all utility lines, structures and appurtenant facilities of the Commission.

The structures and appurtenant facilities installed by the Commission shall be and remain the property of the Commission and may be removed by it at any time and from time to time.

Grantor reserves the right to use the lands in and over which the right of way and easement rights are hereby granted for all purposes not inconsistent with said right of way and easement rights, except that Grantor agrees that (1) no buildings or permanent structures, wells, septic tanks, absorption pits, underground or overhead storage tanks, burial plots, or any other obstruction which might interfere with the construction, maintenance and operation of said utility facilities shall be placed within the area of said strip without the express written permission of the Commission; and (2) the Commission's facilities shall in no way be interfered with or endangered by the Grantor or Grantor's licensees, successors or assigns, without the express written permission of the Commission.

The Commission agrees that it will repair, rebuild, replace or pay the actual damages sustained as mutually agreed upon by the Commission and Grantor, and pay the actual damages to actual crops inside said right of way strip on the above land caused by the construction, operation, maintenance, inspection, rebuilding and removal of said lines, and in going to and from said right of way strip, and will repair any extraordinary damage to any bridge or to any road due to heavy hauling to and from the said right of way strip if claim is made within a period of thirty (30) days after such damages are sustained by Grantor.

Any notice to be given by one party to the other party hereunder may be delivered or deposited postage prepaid addressed to the following:

Grantor:	Name:	State of North Carolina
	Address:	Department of Administration Administration Building c/o State Property Office 116 W. Jones Street
	City/State/Zip:	Raleigh, NC 27603
Commission:	Greenville Utilities Commission 401 S. Greene Street P.O. Box 1847 Greenville, North Carolina 27835-1847	

TO HAVE AND TO HOLD the aforesaid rights, privileges and construction easement unto the Grantee for such period of time as may be required to complete the construction of said utility facilities, and thereafter a permanent easement unto the Grantee and its successors, licensees and assigns for the uses and purposes hereinabove set forth.

And Grantor, for the Grantor and for the Grantor's heirs, executors, administrators, licensees, successors and assigns, covenants to and with the Commission, its licensees, successors and assigns, that Grantor is lawfully seized of the above described land in fee and has the right to convey the said rights, easements and privileges herein described; that the same is free and clear from any and all encumbrances not satisfactory to the Commission; that the

Commission shall have quiet and peaceful possession, use and enjoyment of the
aforescribed easement of right of way, rights and privileges; that the Grantor shall execute
such further assurances thereof as may be required by the Commission; and Grantor will
forever warrant and defend the title to the said easement of right of way, rights and privileges
against the lawful claims of all persons whomsoever.

The singular shall include the plural and reference to gender shall include masculine,
feminine and neuter.

IN TESTIMONY WHEREOF, the STATE OF NORTH CAROLINA has caused this
instrument to be executed in its name by BEVERLY E. PURDUE, Governor, attested by
ELAINE F. MARSHALL, Secretary of State, and the Great Seal of the State of North Carolina
to be hereto affixed by virtue of the power and authority aforesaid.

STATE OF NORTH CAROLINA

By: _____ (SEAL)
BEVERLY E. PURDUE, Governor

ATTEST:

By: _____
ELAINE F. MARSHALL, Secretary of State

APPROVED AS TO FORM:

ROY COOPER
ATTORNEY GENERAL

By: _____
Assistant Attorney General

NORTH CAROLINA

COUNTY of _____

I, _____, a Notary Public in and for the aforesaid
County of _____, State of North Carolina, do hereby certify that ELAINE F.
MARSHALL, Secretary of State of North Carolina, personally appeared before me this day and
acknowledged that she is Secretary of State of North Carolina, and that by authority duly given
and as the act of the State, the foregoing instrument was signed in its name by BEVERLY E.
PERDUE, Governor of the State of North Carolina, sealed with the Great Seal of the State of
North Carolina, and attested by herself as Secretary of State of North Carolina.

IN WITNESS WHEREOF, I have hereunto set my hand and Notarial Seal, this the
____ day of _____, ____.

NOTARY PUBLIC

Print Name: _____

My Commission Expires: _____

NORTH CAROLINA

PITT COUNTY

The foregoing certificate(s) of _____, a Notary Public of the
aforesaid County and State, is/are certified to be correct.

This the _____ day of _____, _____.

REGISTER OF DEEDS, PITT COUNTY,
NORTH CAROLINA

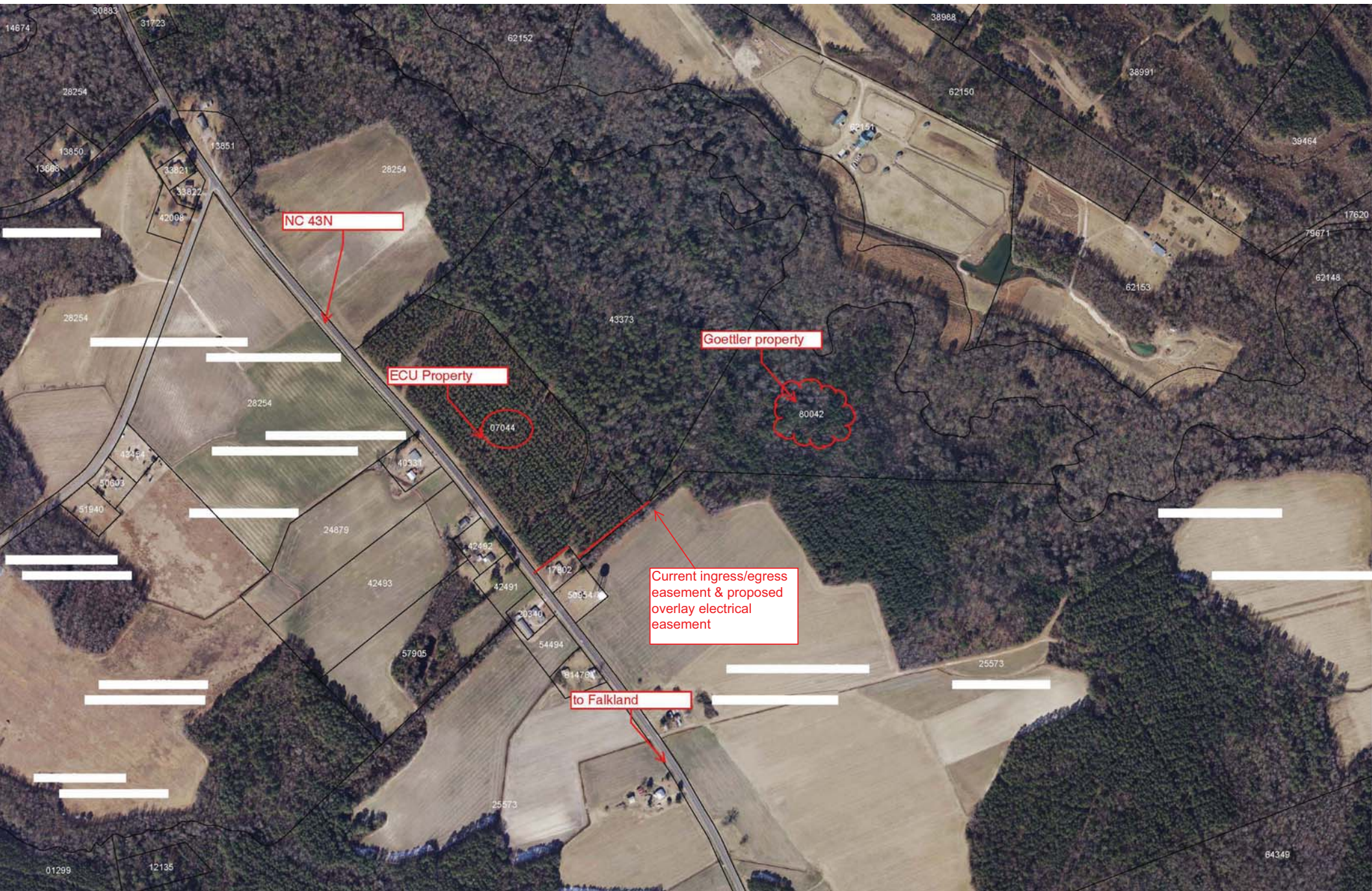

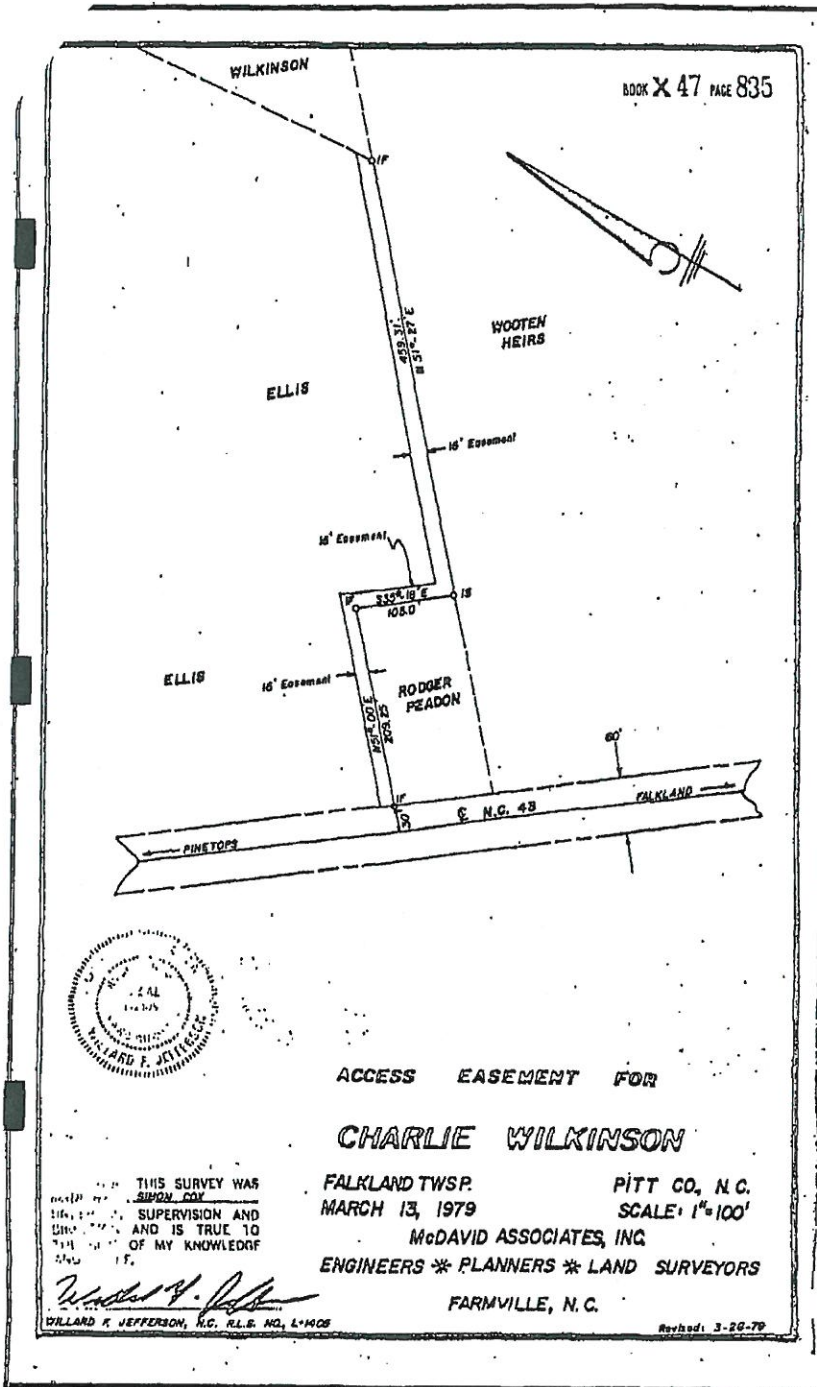

BOOK X 47 PAGE 835



ACCESS EASEMENT FOR

CHARLIE WILKINSON

FALKLAND TWSP. PITT CO., N.C.
 MARCH 13, 1979 SCALE: 1"=100'
 McDAVID ASSOCIATES, INC
 ENGINEERS * PLANNERS * LAND SURVEYORS
 FARMVILLE, N.C.

THIS SURVEY WAS
 SUPERVISED AND
 CONTROLLED BY ME
 AND IS TRUE TO
 THE BEST OF MY KNOWLEDGE

Willard F. Jefferson
 WILLARD F. JEFFERSON, N.C. R.L.S. NO. 14108

Revised: 3-28-79

PURPOSE and VISION

The goal of this document is to develop a joint statement and plan on behalf of East Carolina University, TRUNA, and the City of Greenville to promote and encourage the long-term stability and viability of the Fifth Street corridor and Tar River University Neighborhood. While it is clear that much has changed since 1907, we will jointly commit to working together as a team to prevent the deterioration of the Tar River University Neighborhood area. For the purposes of this vision statement, the boundaries will include Reade Street to Elm Street and 5th Street to 1st Street.

All relevant parties involved in this discussion share much common ground: we all desire for this area to maintain its historic ambiance – it sets the tone for the welcoming community that we want to protect. Additionally, all constituencies in this area of the community have mutual respect and appreciation for each other and want to encourage consistent and open communication among all involved. All parties agree that it is important for the neighborhood to maintain a sense of its past and retain a primarily residential feel, yet also be open to new uses that are complementary to a residential neighborhood.

ECU, TRUNA, and the City of Greenville commonly support the following key principles and common objectives to sustaining this important area of the Greenville community:

KEY PRINCIPLES of a SUCCESSFUL PARTNERSHIP

- Effective Communication
- Active Participation and Involvement
- Commitment to Improved Relationships
- Respect and Trust

COMMON OBJECTIVES

- Viable, sustainable, and preserved historic character of the community
- Pedestrian and bicycle friendly community
- Safe environment
- Social and friendly
- Diverse
- Support an owner/rental balance by citizens vested in the community
- Mixed Use – Office, Education, Commercial, and Residential where appropriate

As we continue to strive for the long-term stability of this area, we agree to cooperatively undertake the following action items in an effort to encourage consistent attention to this need for our community:

ACTION ITEMS

- The President of TRUNA, the Director of Community Development for the City of Greenville, and the Executive Assistant to the Chancellor at ECU will meet on a regular basis throughout the year to maintain open communication among all organizations.
- This document will be reviewed on an annual basis.
- ECU and the City of Greenville will work to maintain a strong police presence in the Tar River Neighborhood and serve the community in that area as identified in the City-ECU policing agreement.
- Pending a yearly review, measurable success, and budget availability, ECU will continue to work with the City to support code enforcement in the Tar River Neighborhood area as identified in the current agreement.
- All organizations will work cooperatively on zoning and historic preservation issues and recognize that changes may be necessary.

This vision statement is respectfully accepted this XX day of MONTH 2011.

Bert Powell, President of TRUNA _____

Pat Dunn, Mayor _____

David Brody, ECU Board of Trustees _____

Health Sciences Committee

February 2011

PCMH Update - Steve Lawler, President of PCMH, reported:

- Working with the BSOM to improve the Graduate Medical Education (GME) model – i.e., how it is put together, funding, and opportunities to expand it.
- Clinical innovation and alignment - working with the Health Sciences Division (BSOM, Allied Health, Nursing, & Dentistry) on new innovative models of care and alignment of services.
- Project updates - renovating the call rooms for residents & fellows; Children's Hospital – ground breaking in June 2011; Pediatric ED – a separate dedicated space to care for children which will be located within the ED.
- Legislative agenda for UHS/PCMH is the tied together with the BSOM – i.e., Upper Payment Limit/Medicaid funding and GME Expansion.

Dr. Horns shared from the Division:

- The Health Sciences Division Senior Leadership has been working on a draft of the Strategic Action Plan for the Division.
- School of Dental Medicine – **first class will begin in August 2011**; acceptance letters have been issued – **all NC residents; received ADEA initial accreditation in early February**; several faculty and staff searches are underway; working on a innovative, integrated, and complex curriculum model which will give a comprehensive approach to tracking student learning and progress, construction of the Ross Hall is underway and on track for the Class of 2012; will assume the General Practice Residency program at the BSOM by July 2011.
- East Carolina Heart Institute 4th Floor – building was finished 3 years ago without the 4th floor being completed. 4th floor was intended for research space -- designated for interdisciplinary kinds of research for faculty across multiple disciplines (i.e., Life Sciences programs in BSOM; College Health and Human Performance, Department of Bioenergetics). The Robotics Lab will also be located on the 4th floor. Construction to begin December 2011/January 2012.
- Programs in the Health Sciences Division are very competitive, there are no underperforming programs; outcomes of our graduates demonstrates that our programs are outstanding (i.e., performance on licensure exams and placement of graduates in the workforce)

BSOM Update:

- Dr. Cunningham reported that the BSOM leadership is working to build the BSOM Strategic Plan and has created mind maps and outcomes for the future.
- Dr. Benson reported on the:
 - Cancer Services Joint Venture – The joint venture will kick off on April 11, 2011 and it will be called the **Leo Jenkins Cancer Services Corporation**. Leases are being reviewed, 3 CONs were approved by the State CON section; an administrator has been hired; details of the transition process for the employees to be employed by ECU or PCMH are being worked out. The new Department of Oncology is being further developed.
 - Health Span Conversion Update – on-line at Firetower Medical Office, ECU Physicians, Internal Medicine, and Cardiovascular Sciences. 5 departments still

remain on the old system, Centricity. Working with UHS on the best approach to get the remaining departments on-line.

- Mr. Jowers reported on ECU Physicians financial performance. Total charges billed are down by 1%; wRUV's are down by 2.3%; all other indicators are positive. Continuing to work closely with the Department Chairs to ensure timely invoicing of contract revenues and follow-up on outstanding receivables.

University Affairs Committee

Campus Safety – Bill Koch

- Bill introduced a few new members of the ECU family that deal with safety.
 - Travis Lewis - Dean of Students Office - Helping coordinating threat assessment for students
 - Lt. Jason Sugg with the ECU police department, a recent graduate of the FBI National Academy
 - Sgt. Kevin Stormer a strong liaison between ECU and the Greenville Police Department
- Bill discussed the recent release of information from the Virginia Tech shooting. We have all learned lessons from these situations. At ECU, the police department now has the clearance to release ECU alerts to campus when the situation arises. There will be an Active Shooter drill in August on the medical campus planned.
- Part 1 crimes are lower on our campus with about 90% of the crimes are larcenies
- ECU is developing a mandatory safety training to roll out in the fall to strengthen our education of students. We want to push this information out in front of students, in particular, with incoming freshmen early in their first semester.
- The blue light emergency phones are being updated from analog to digital which will allow for cameras and monitors to be attached. We are also changing the post colors to purple or gold for better visibility.

Academic Affairs –

- Dr. Austin Bunch, Dr. Elmer Poe and Dr. Rosina Chia discussed the Global Academic Initiatives program. ECU has partnerships with 30 universities in 22 countries to collaborate and educate on cultural understanding on a global scale. He shared some of the accolades and awards for international innovation and global engagements, including the US Department of State's request for ECU to offer academic curriculum on Global Climate Change and policies.
- Rosina shared some of the core functions of the Global Understanding Course include the courses (Anthropology, Psychology, Sociology and International Studies) which are delivered in real-time video instruction and collaboration. 1,500 students each year are impacted by this course with four college partnership working together for five week sessions. All course sections are delivered in English. Some of the benefits to ECU students include better global perspectives, better understanding of our own culture, increased communication skills, and stronger job opportunities and skills. For ECU as a whole, this is a great cost and time saving piece because we aren't traveling, but still participating and it is a great complement to study abroad.

Athletics – Terry Holland

- The softball stadium was dedicated and opened up with a win over UNC Wilmington last week.
- Nick Floyd informed more updates on the other facilities with the track and soccer complexes being slated for completion this spring. The team facility is going to bid and hopeful for completion in the next year.
- The basketball practice facility is moving along and \$9 million of the \$15 million goal has been raised and we are moving forward with design and development.
- Nick said the goal was to keep the season ticket price at the same rates from last year, so the South Carolina game is not included in the season ticket package.

The University Affairs adjourned after a closed session



Tenure Approvals
February 25, 2011

Academic Affairs

Academic Library Sciences

May Chang (New Hire)
Nara Newcomer
Dale Sauter
W. Joseph Thomas
Hazel Walker

Harriot College of Arts & Sciences

Michael Albers
Allison Danell
Slobodanka Dimova
Thomas Herron
Jinling Huang
Andrew Jacobs
Lesley Lutes
Christopher Oakley
Michael O'Driscoll
Kenneth Parille
Mona Russell
Benjamin Saidel
David Smith
Tuan Tran
Liza Wieland
Derrick Wirtz

College of Business

Joy Karriker
Huigang Liang
L. Melita Prati
Yaijong Xue

College of Education

Lora Lee Smith Canter
Jamin Carson
Kristen Cuthrell
Jami Jones
Lane Mills
Marjorie Ringler
Karen Voytecki
Larry Nash White
Jennifer Williams

College of Fine Arts and Communication

Matthew Egan
Jorge Richter

**College of Health and Human
Performance**

Katrina Dubose
Anthony Kulas

College of Human Ecology

Lena Carawan
Archana Hedge
Kimberly Heidal
Erin Parrish
David Rivera

**College of Technology and Computer
Science**

David Batts
Qin Ding
Eugene Dixon
William Howard
Richard Williams
Jianchu Yao

Health Sciences

College of Allied Health Sciences

Martha Chapin

Sherri Jones

Michael Kennedy

Thomas Ross

College of Nursing

Elizabeth Jesse

Brody School of Medicine

Curtis Anderson

Diana Antonacci

Eric Bailey

David Collier

Janet Malek

Barbara Muller-Borer

Stanley Oakely

Evelio Rodriguez

Michael Stoner

School of Dental Medicine

Linc Conn (New Hire)

Stuart Josell (New Hire)